

MECHRON POWER SYSTEMS

Rugged. Proven. Trusted.

Product Sheet



Mechron Power Systems

2437 Kaladar Avenue
Ottawa, Ontario
Canada K1V 8B9

Tel: (613) 733-3855
Fax: (613) 733-8197

www.mechron.com

A Division of
Toromont Industries Ltd.

Cycle Charge™ DC Power System For Standalone and Hybrid Applications

Cost savings and increased reliability – this is what Mechron's Cycle Charge™ DC Power System is all about. By combining proven DC power generation with advanced control systems, Cycle Charge™ can be seamlessly integrated in many applications, dramatically reducing the overall costs and increasing system reliability.



What is Cycle Charge?

Cycle Charge™ is a DC-based power generation system designed to replace conventional AC prime power systems in a wide variety of applications. In a Cycle Charge™ system, the AC generator and DC power supply are replaced with a DC generator, station batteries and high-efficiency inverters for AC loads. The station batteries supply prime power, with the DC generator set cycling on when required to recharge the batteries to an optimal state of charge.

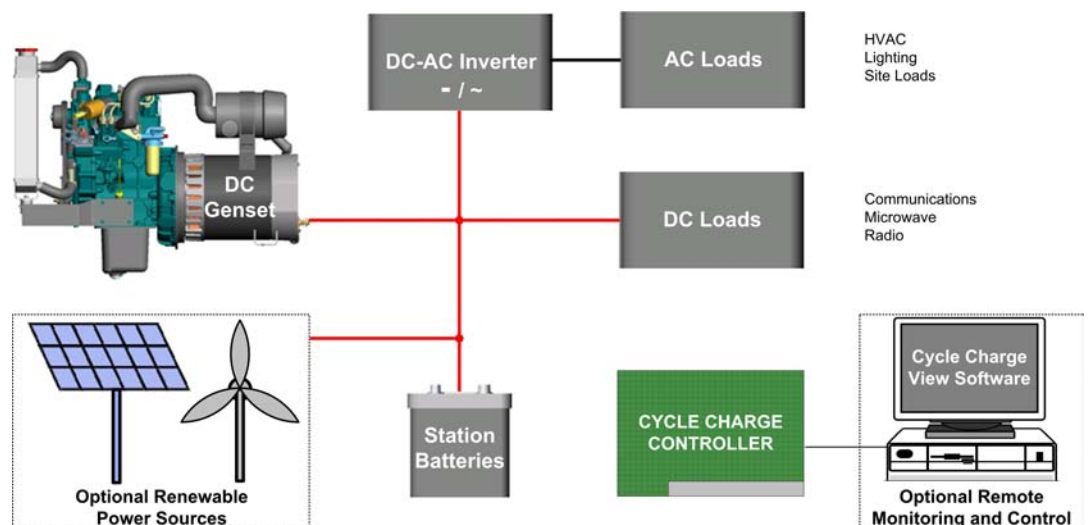

BENEFITS

Reduced Costs

In the Cycle Charge™ system, the DC generator only operates when needed and always at maximum efficiency. This significantly reduces fuel consumption and engine wear, resulting in cost savings of up to 70% when compared to a conventional prime power system. A hidden benefit is the savings in maintenance visits – always expensive, even more so in a remote application.



Mechron Power Systems
2437 Kaladar Avenue
Ottawa, Ontario
Canada K1V 8B9

Tel: (613) 733-3855
Fax: (613) 733-8197

www.mechron.com

A Division of
Toromont Industries Ltd.

Upfront costs are also reduced. By using the system batteries to supply the load, the size of the DC generator can be reduced significantly. This results in lower costs not only for the generator but also for the site, reducing requirements such as fuel storage, building size and HVAC requirements.

	CYCLE CHARGE	CONVENTIONAL
Annual run hours:	2,046	8,760
Average diesel off-time:	14.2 hours	Non-stop
Average diesel on-time:	3.5 hours	Runs Continuously
Annual fuel consumption:	800 gal / 3637L	4,000 gal / 18184L
Annual fuel savings:	3,200 gal / 14547L	-
Annual site visits:	2-4	18
Annual system cycles:	494	Runs Continuously

Sample Cycle Charge™ System Performance Comparison

Increased System Reliability

Through a combination of intelligent controls and redundancy, Cycle Charge™ provides significant improvements in system reliability. In the event of battery failure, the control system allows the DC generator to operate in fail-safe mode, supporting the system load until the problem is remedied. When equipped with optional Cycle Charge View™ software for remote monitoring, problems are immediately reported, allowing for rapid correction.

Seamless Integration



By providing DC power directly to the battery and load, Cycle Charge™ can be easily installed in a new system or replace an existing prime power system. Cycle Charge™ integrates seamlessly and cost effectively with power sources such as wind power and solar power, creating a reliable uninterrupted hybrid power system with all the benefits of environmentally friendly renewable power.

Advanced Control System

Cycle Charge™ systems are equipped with an advanced control system, monitoring essential aspects of the power system and ensuring the most reliable and cost effective operation possible. The control system is designed for maximum flexibility to site requirements, with auxiliary controls for HVAC and other functions as necessary.

Remote Monitoring and Control Software

Cycle Charge™ systems can be equipped with optional Cycle Charge View™ software, allowing for remote control and monitoring of one or many Cycle Charge™ systems. Cycle Charge View™ software is ideal for remote or critical applications, where problems have to be identified and resolved as quickly as possible.



Mechron Power Systems
2437 Kaladar Avenue
Ottawa, Ontario
Canada K1V 8B9

Tel: (613) 733-3855
Fax: (613) 733-8197

www.mechron.com

A Division of
Toromont Industries Ltd.

Hybrid Management System (HMS) – Maximum Efficiency

Cycle Charge™ systems are available with Mechron's Hybrid Management System (HMS). The HMS optimizes multiple power sources, maximizing the use of renewable sources such as wind and solar power and minimizing the use of non-renewable sources such as utility and generator set power.

Proven Technology

Mechron is an industry leader in the use of DC power in its Cycle Charge™ system. Cycle Charge™ has been proven through over 20 years of use in some of the most difficult environments conceivable. Many of the technologies used in Cycle Charge™ systems are now employed in today's highly efficient hybrid-electric vehicles. Through the use of proven DC power generation systems and controls, the Cycle Charge™ ensures reliable power for your application.

A Complete Solution – Turnkey Systems

Cycle Charge™ is a complete power system solution. Cycle Charge™ takes the worry out of integration by providing a turnkey system, complete with installation, commissioning and site control as required. Mechron's Cycle Charge™ systems can be supplied in secure, relocatable shelters.

Service and Support

As with all Mechron products, Cycle Charge™ systems are backed by comprehensive service and support. Extended service arrangements are available, including preventive maintenance, emergency repair and overall site maintenance.

CYCLE CHARGE™ SYSTEM SINGLE LINE SCHEMATIC

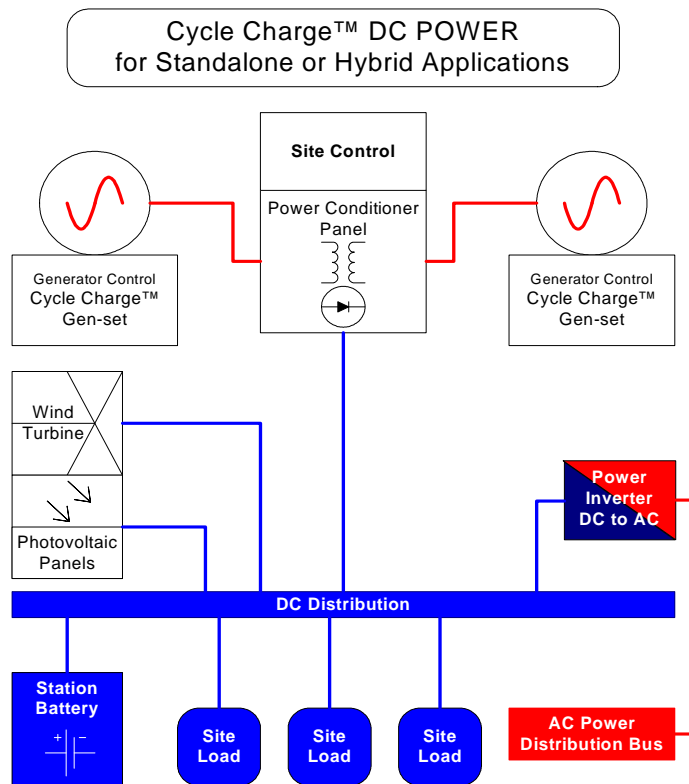

Mechron Power Systems

2437 Kaladar Avenue
Ottawa, Ontario
Canada K1V 8B9

Tel: (613) 733-3855
Fax: (613) 733-8197

www.mechron.com

A Division of
Toromont Industries Ltd.

SPECIFICATIONS

DC Output Voltage	12, 24 or 48 Volts (Pos or Neg Ground)
Output Charging Current	50 to 500 A DC
Operating Temperature Range	-60°C to +50°C
DC Electrical Noise	25 dBrc (10 dBrc available)
Station Batteries	Deep cycle, sized to load and system requirements
AC Output Voltage	As required

OPTIONS

- Cycle Charge View™ Remote Monitoring and Control System
- Hybrid: Solar array or wind power input
- HMS – Hybrid Management System
- High efficiency inverters for critical AC loads
- Maintenance free station batteries best suited to your application
- Custom indoor and outdoor fuel systems
- Low loss damper systems for improved thermal efficiency
- Integrated environmental and fire control systems
- Complete Packaged systems including shelters to suit the environment
- Extended service agreements